

TOP VIEW

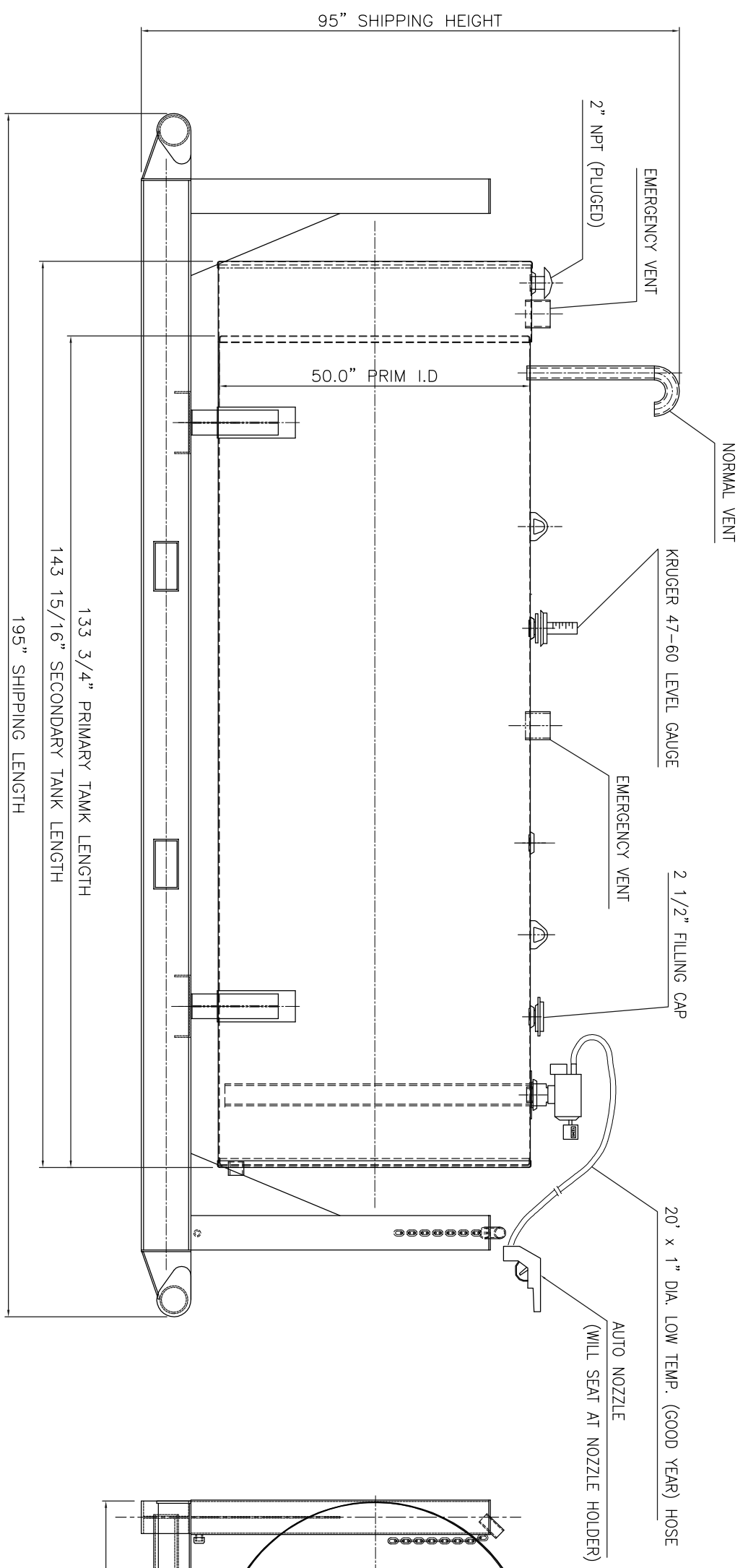

SIDE ELEVATION

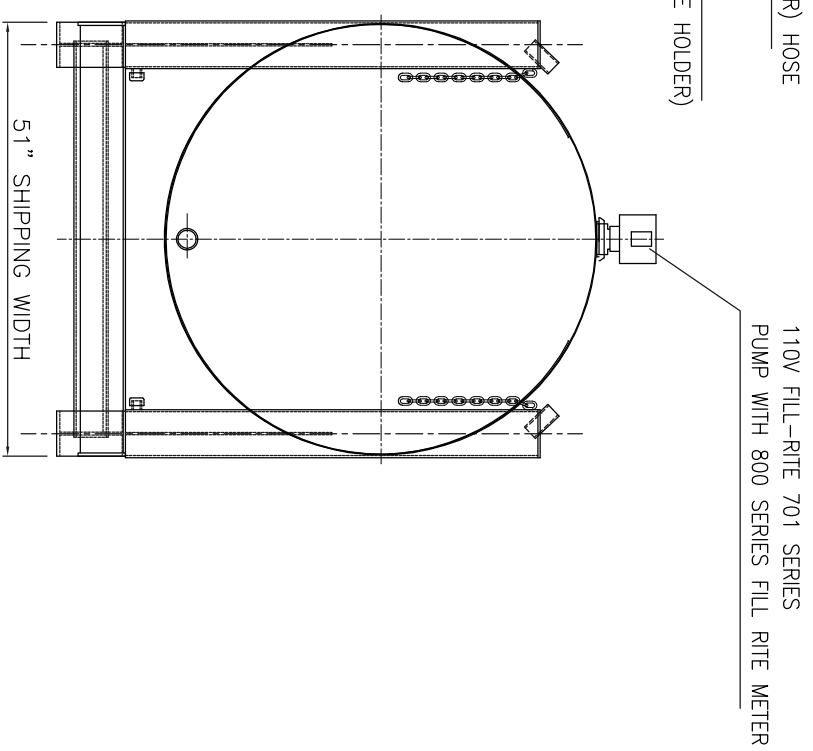

END VIEW

0	ISSUE FOR APPROVAL	DEC. 5, 08	AP	TD
REV.	DESCRIPTION	DATE	DRAWN	APPROD.
<input type="checkbox"/> QUOTE		<input type="checkbox"/> CONSTRUCTION		<input type="checkbox"/> INFORMATION
TANKS DIRECT		11735, 231 STREET		EDMONTON, AB T5S 2G5
TANKS DIRECT		11735, 231 STREET		EDMONTON, AB T5S 2G5



UIC: S601/S653  
 GENERAL ARRANGEMENT  
 4328 LTRS

W.O. NO.	NO. OF	DRAWING NO.	REV.
TD-0001	ONE	4328-LTRS-002	R0

SCALE: NTS FILE NAME : 4328-LTRS-002