

TANK KIT CONTENTS (277726R)		
QTY	PART NO.	DESCRIPTION
1	198900	MANUAL - RECYCOIL USED OIL TANK
1	276734	VENT 2" ATMOSPHERIC
1	277737R	R1100 RECYCOIL TANK

TANK FEATURES					
MARK	Qty	DESCRIPTION	REMARKS		
N1	1	24" SPILL BOX - c/w: - REMOVABLE FILL SCREEN PLATE - 2" NPT w/ CAMLOCK & DUST CAP - 2" INTERNAL SUCTION PIPE	60L MINIMUM CAPACITY FOR SPILLBOX FILL FOR TANK SUCTION CLEANOUT		
		N2	1	2" NPT c/w VENTED POLY PLUG	PRIMARY TANK NORMAL VENT PORT
		N3	1	2" NPT c/w M.I. PLUG	GAUGE
N4	1	2" NPT c/w M.I. PLUG	SPARE		
N5	1	2" NPT c/w M.I. PLUG	OUTLET/GAUGE		
N6	1	2" MNPT c/w VENTED INSPECTION CAP	SECONDARY INSPECTION/VENT PORT		
A	4	FORMED SUPPORT LEGS			
B	2	LIFT LUG			
C	1	ULC NAMEPLATE			

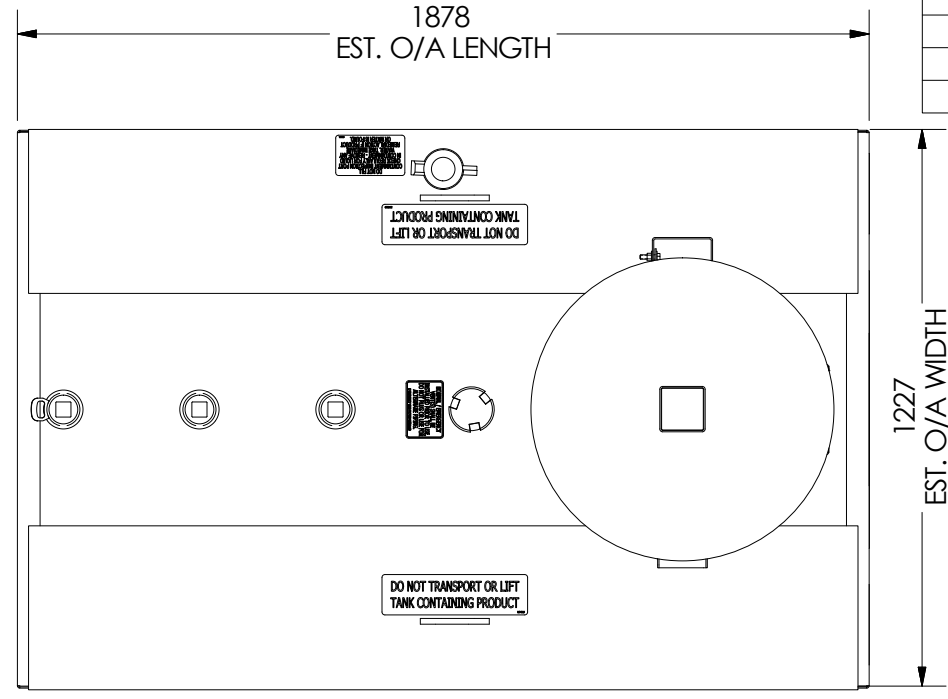
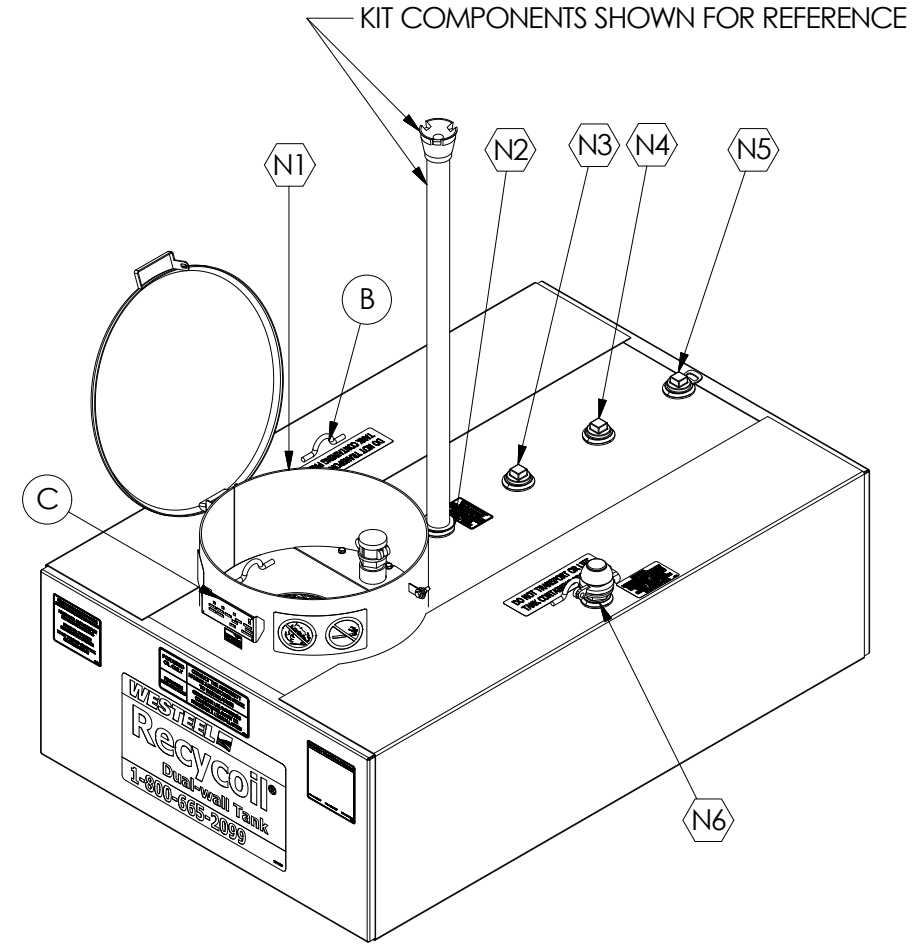

- NOTES:
- SEE TANK SPECS.
  - PRIMARY TANK AND CONTAINMENT WRAP AIR/SOAP LEAK TESTING: 35 kPa (5.0 PSI)
  - DIMENSIONS & CAPACITY MAY VARY DUE TO MANUFACTURING TOLERANCES.
  - DECALS: WESTEEL AND ULC STANDARD DECALS ARE INSTALLED AS REQUIRED.
  - EXTERIOR FINISH - PHOSPHATE WASH, POWDER COAT WHITE. INTERIOR FINISH - AS WELDED
  - NORMAL VENT MUST BE INSTALLED PRIOR TO USE.

TANK SPECIFICATIONS:  
 FABRICATION CODE: ULC-602-14 AND ULC S652-16  
 TANK TYPE: CLOSED SECONDARY CONTAINMENT  
 NOMINAL CAPACITY: 1135 L  
 PRIMARY METAL THICKNESS: 2.3 mm  
 SECONDARY METAL THICKNESS: 2.3 mm  
 MAX OPERATING PRESSURE: 7 kPa  
 MAX OPERATING VACUUM: 300 Pa  
**NOT STACKABLE**  
 LIFT LUGS **NOT** CERTIFIED TO LIFT TANK CONTAINING PRODUCT

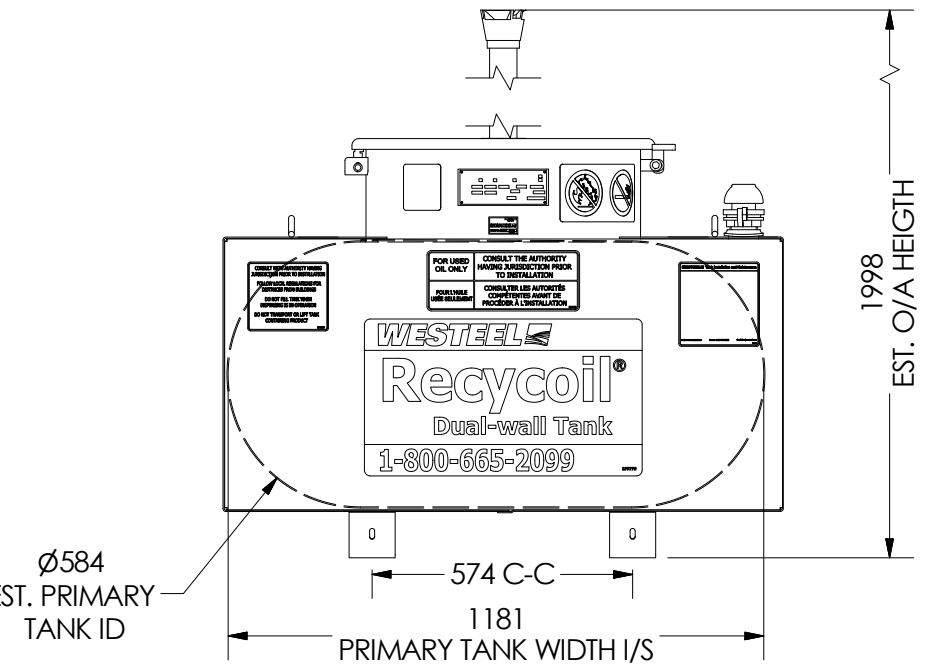
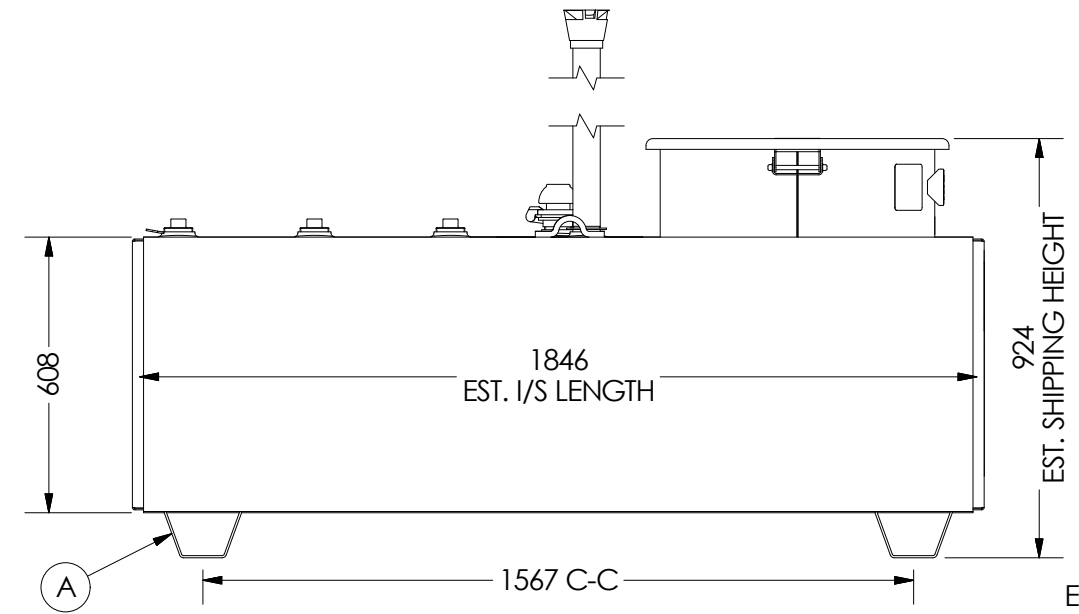

REV	DATE	DESCRIPTION	ECR#	BY	CHK'D.
5	12/1/2017	ADDED NORM + EM. VENTING CAPACITY	L10312C	NJK	KA
4	23 MAR 16	CREATED INVNTOR DWG, CHG SEC WALL DIMS, REDUCED FLG SPACE TO 300MM	L10285C	FR	CDS
3	12 MAY 15	PN 530630 TO 264219	L10256R	CDS	KA
2	30 APR 13	UPDATE BOMS FOR SAP, ADD SERIAL DCL, CHG 105073 TO 074	L10131C	CDS	KA
1	15 JAN 13	272927 WAS 530746	L10115C	HWU	KA
0	13 APR 12	ISSUED FOR PRODUCTION	L10073R	NJK	KA
A	13 FEB 12	ISSUED FOR REVIEW		NJK	SLS

DIMENSIONS SHOWN ARE MM IMPERIAL UNITS ARE IN BRACKETS	DESND. CDS	DATE 8/14/2015
TOLERANCES (UNLESS OTHERWISE NOTED)	DWN. FR	DATE 3/23/2016
DIMENSIONS: METRIC (mm) IMPERIAL (in.)	CHKD.	DATE
x ± 2      .x ± 1 .x ± 1.0    .xx ± .03 .xx ± .50   .xxx ± .010	APPD.	DATE
ANGULAR: ± 1°		

	This drawing is the exclusive property of WESTEEL and all rights are reserved. No part of this drawing may be used or reproduced in any manner whatsoever without written permission from WESTEEL.	
	DRAWING TITLE R1100 RECYCOIL TANK GENERAL ARRANGEMENT	
	CUSTOMER WESTEEL DESIGN STANDARD	

CALCULATED WEIGHT N/A	LOCATION 5067
QUOTE NO.	ORDER NO.
DRAWING NO. 277737R	REV. 5
	SHEET 1 of 1